

Pre-punched Tap Hole Guide

Applicable for Sergio Granite Sinks

Important

The granite “hole plug” must be removed prior to installation of the sink by a professional. Failure to do so will void the warranty.

Due to individuality of these sinks we strongly recommend that a registered joiner / plumber be used to complete the install.

Tools Required



Sharp Ended Nail Punch

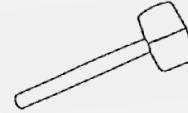

Hammer



Pencil or Marker

Notes

It is highly recommended that filter/respiratory mask, safety goggles and gloves are worn when knocking through the tap hole.

Procedure

1. Area of pre-punched holes are identified with a red dot sticker. View the underside of the sink to identify the centre.
2. Identify the centre of the pre-punched hole that you wish to use. Mark the centre on the top side of the sink. **DO NOT try to knock out the hole from the underneath (Fig. 1).**
3. Place the sink in a well supported position.
4. Take a sharp ended nail punch and placing a soft cloth underneath, place the point onto the mark made. Using a rubber hammer, strike firmly the top of the punch until the point has been broken through to the underside of the pre-punched hole (**Fig.2**). The granite “hole plug” should drop out in one piece
5. Carefully chip away the remaining material to gradually enlarge the tap hole if a larger space is required (**Fig.3**).
6. You should then find the tap mixer you intended to use, will fit the hole.

Cleaning Up

Ensure any residue from the removal is vacuumed up, tools and equipment thoroughly cleaned.

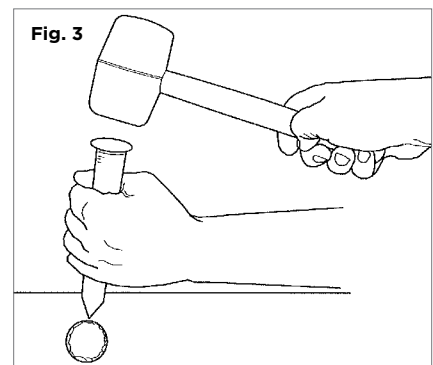
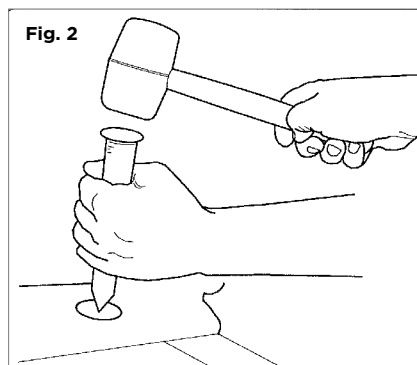
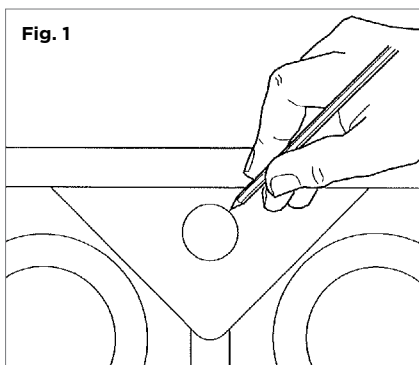

Due to our policy of continual improvement, we reserve the right to change specifications without prior notice.